

2024

## ENGINEERING DRAWING

(Theory)

Full Marks : 70

Pass Marks : 21

Time : Three hours

**Instructions :**

- (i) Attempt all the questions.
- (ii) All dimensions are in millimeters.
- (iii) Missing and mismatching dimensions, if any may be suitably assumed.
- (iv) Use both sides of the drawing sheet if necessary.
- (v) Follow the SP : 46-2003 revised codes, (With first angle method of projection) if not mentioned.

Answer the following Multiple Choice Questions and rewrite the correct choice on your drawing sheet.

1×5=5

1. A tangent touch a circle at \_\_\_\_\_ .  
(i) 4 points            (ii) 1 point    (iii) 2 points    (iv) All of these
2. How many principal planes are there in Orthogonal projection.  
(i) 1                    (ii) 2                    (iii) 3                    (iv) 4
3. Which angle of projection is recommended by Bureau of Indian Standard for Engineering Drawing in India?  
(i) First angle        (ii) Second angle    (iii) Third angle    (iv) Fourth angle

P.T.O.

4. Circle in isometric projection appears as a/an \_\_\_\_\_.
- (i) Cone                      (ii) Circle                      (iii) Ellipse (iv) Cylinder
5. When the axis of a regular solid is perpendicular to V.P. then its base will be seen in :
- (i) Front view                      (ii) Top view                      (iii) Side view (iv) None of these

Answer the following questions :

6. Construct a Right-angled Triangle ABC, having its hypotenuse AC = 60 mm and the difference of its hypotenuse and one side equal to 25 mm.                      4
7. Construct a regular pentagon with base AB = 40 mm, using protractor and inscribe a circle in it.                      5
8. Describe an Ellipse about a given triangle CAB whose base AB = 60 mm, sides AC = 50 mm and CB = 30 mm.                      5
9. A regular pentagon ABCDE of 30 mm sides, is having a side parallel to V.P. and close to the observer and its surface is inclined to H.P. at  $45^\circ$  but perpendicular to V.P. Draw its front view and top view.                      10

**OR**

A circle of 50 mm diameter is having its surface making  $45^\circ$  with H.P. and perpendicular to V.P. Draw its front view and top view.                      10

10. A Hexagonal Pyramid of 25 mm base edges and 60 mm long horizontal axis, is resting on one of its base edges on H.P. parallel to V.P. with its vertex on the rear. It is cut by a Horizontal Plane, 10 mm above its axis. Project its Front View and Sectional Top View.                      15

**OR**

A cylinder of 40 mm diameter and 55 mm horizontal axis, resting on H.P. with its axis inclined to V.P. at  $30^\circ$  towards the left, is sectioned by a Horizontal Plane 15 mm above its axis. Project its Front View and Sectional Top View. 15

11. Draw to scale 1: 1, the following views of the machine block shown in Fig. - 1. (Use First Angle Projection method). 12

- (a) Front View looking in the direction of arrow 'a'.
- (b) Side View as seen from right.
- (c) Top View.

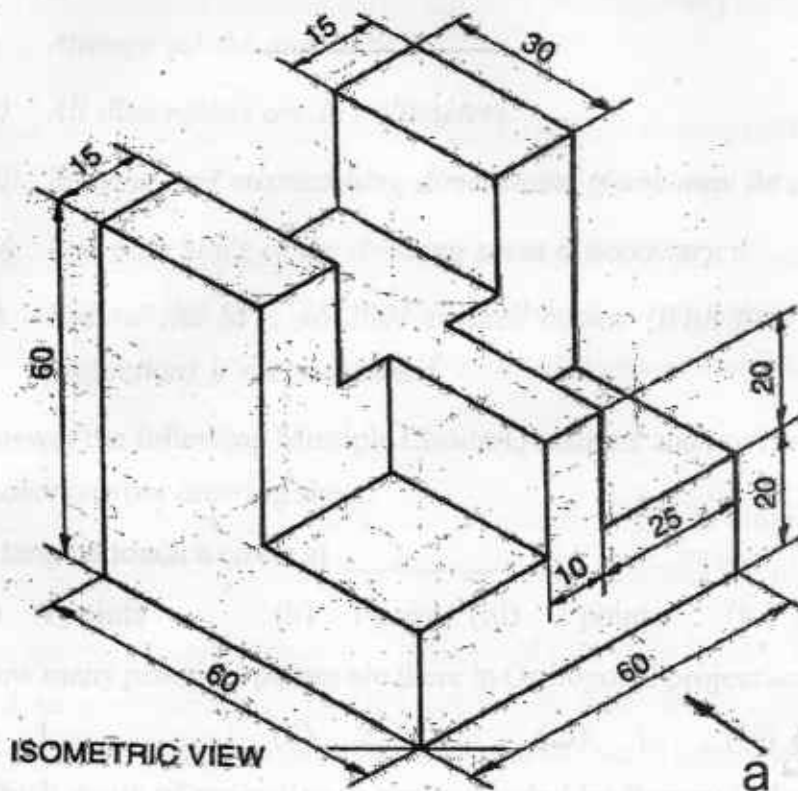

Fig. - 1

12. Draw an Isometric projection of a pentagon with 38 mm sides having its surface parallel to V.P. and perpendicular to H.P. and a side resting on H.P. 9

Or

12. Draw an isometric projection of a circle having its diameter equal to 42 mm standing on H.P., with its surface parallel to V.P. 9

13. Draw the development surface of a cone, base diameter 30 mm and height of the cone 50 mm. 5

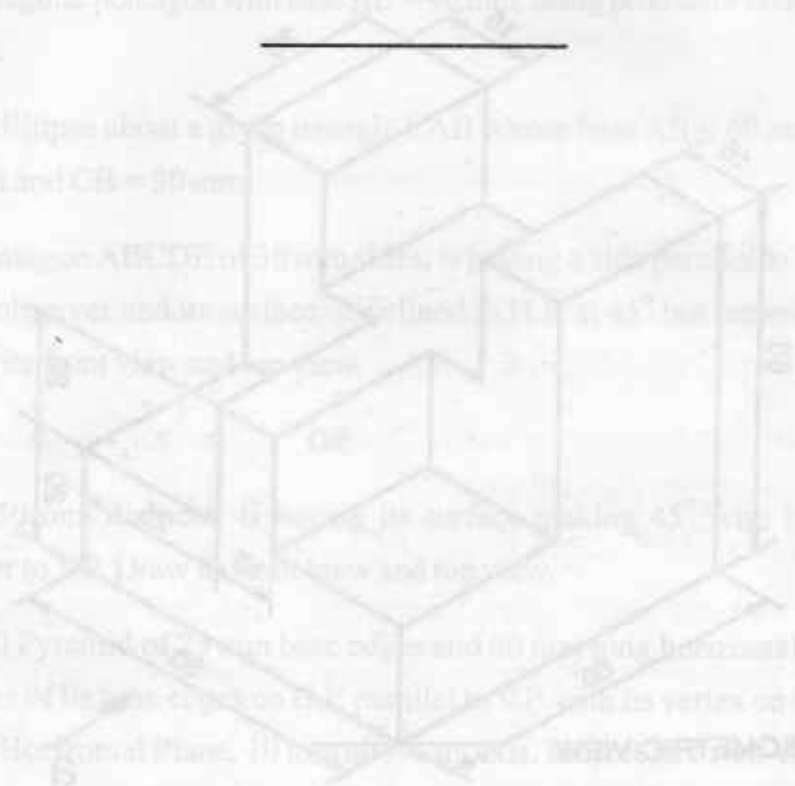

OR 1-3/4