

2023

ENGINEERING DRAWING

(Theory)

Full Marks : 70

Pass Marks : 21

Time : Three hours

Instructions :

- (i) *Attempt all the questions.*
- (ii) *All dimensions are in millimeters.*
- (iii) *Missing and mismatching dimensions, if any may be suitably assumed.*
- (iv) *Use both sides of the drawing sheet if necessary.*
- (v) *Follow the SP : 46-2003 revised codes, (With first angle method of projection) if not mentioned.*
- (vi) *In question 4, hidden edges or lines are to be shown in views without section.*

1. Answer the following Multiple Choice Questions and rewrite the correct choice on your drawing sheet. 1×5=5

(a) A drafter cannot replace a :

- | | |
|------------------|---------------|
| (i) Protractor | (ii) T-square |
| (iii) Set-square | (iv) Compass |

P.T.O.

- (b) Scale 1 : 1 means :
- | | |
|-----------------------|----------------------|
| (i) Half size scale | (ii) Full size scale |
| (iii) Isometric scale | (iv) All of these |
- (c) A plan of an object is :
- | | |
|-------------------------|-------------------|
| (i) Left hand side view | (ii) Top view |
| (iii) Front view | (iv) All of these |
- (d) When a point lies in H.P its view from the front will be :
- | | |
|---------------------|--------------------|
| (i) On XY line | (ii) Below XY line |
| (iii) Above XY line | (iv) None of these |
- (e) The word 'isometric' means :
- | | |
|-------------------|--------------------|
| (i) Equal Length | (ii) Equal measure |
| (iii) True length | (iv) None of these |
2. Construct a regular Hexagon ABCDEF, having its long diagonal FOC = 50 mm. 4
3. Construct a circle to touch a given straight line AB and to pass through two points C and D, given outside it, at equal distance from it. 5
4. Construct a parabola by intersecting arcs method, having ordinates AE and EB, each = 40 mm and axis EV = 40 mm. 5
5. A Hexagonal Pyramid of 25 mm base edges and 60 mm axis, rest on H.P., on one of its base edges, with the axis inclined to V.P. at 30° , towards the right. Project the Top view and Front view, keeping its axis parallel to H.P. 10

6. A Pentagonal Prism of 30 mm base edges and 55 mm length, is resting on H.P. on one of its base edges, which is perpendicular to V.P. Its base is inclined to H.P. at 60° towards the left. It is sectioned by a Vertical, parallel to V.P. Project its Sectional Front View and Top view. 15
7. Draw to scale 1: 1, the following views of the machine block shown in Fig. – 1. (Use First Angle Projection method). 12
- (a) Front View looking in the direction of arrow.
- (b) Side View as seen from right.
- (c) Top View.

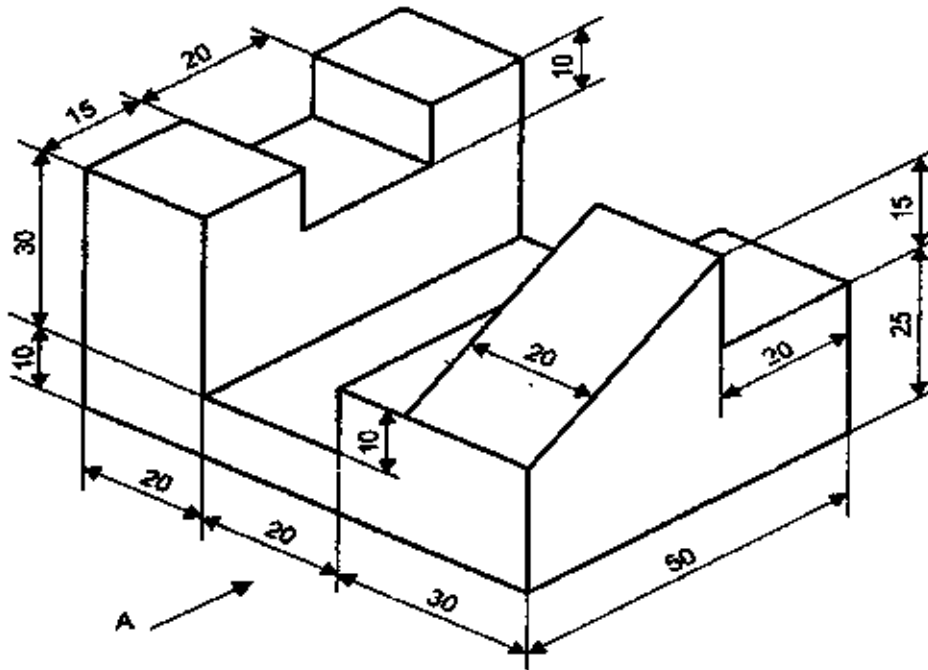

Fig. – 1

8. Construct the isometric projection of a regular hexagon of 30 mm sides, with its surface horizontal and two of its opposite sides perpendicular to V.P. indicate the direction of viewing. Give dimensions. 9
9. Draw the total development surface of a regular hexagonal pyramid, base side 20 mm, height 40 mm on its base on H.P., with a base side parallel to V.P. Give all dimensions. 5
-