

2020

ENGINEERING DRAWING

(Theory)

Full Marks : 70

Pass Marks : 21

Time : Three hours

Instructions :

- I. Attempt all the questions.
 - II. All dimensions are in millimeters.
 - III. Missing and mismatching dimensions, if any may be suitably assumed.
 - IV. Use both sides of the drawing sheet, if necessary.
 - V. Follow the SP : 46 –2003 revised codes, (with first angle method of projection) if not mentioned.
1. Answer the following Multiple Choice Questions. Rewrite the correct choice on your drawing sheet. 1×5=5
- (i) If a circle is drawn, inside another circle with a different centre, it is called _____
 - (a) Semi Circle
 - (b) Concentric Circle
 - (c) Eccentric Circle
 - (d) All of these
 - (ii) How many principle planes are there in Orthogonal projection.
 - (a) 1
 - (b) 2
 - (c) 3
 - (d) 4

(iii) Which angle of projection is recommended by Bureau of Indian Standard for Engineering Drawing in India ?

- (a) First angle (b) Second angle
(c) Third angle (d) Fourth angle

(iv) How many pictorial projection are there ?

- (a) 1 (b) 2
(c) 3 (d) 4

(v) Which projection is known as natural representation ?

- (a) Perspective projection (b) Isometric projection
(c) Oblique projection (d) None of the above

2. Construct a triangle CAB having its perimeter EF equal to 105 mm and its side in the ratio of 4 : 7 : 5. 4

3. Construct a regular hexagon ABCDEF, having its base AB = 25 mm, with the compasses. 5

4. Draw a cycloid, given the diameter of the rolling circle = 42 mm for one complete revolution of the circle. 6

5. A Hexagonal Pyramid of 25 mm base edges and 60 mm axis, rests on H.P., on one of its base edges, with the axis inclined to V.P. at 30° , towards the right. Project the Top view and Front view, keeping its axis parallel to H.P. 10

6. A pentagonal prism of 30 mm base edges and 60 mm length, is resting on one of its long edges on H.P., its Pentagonal end is inclined at 60° , to V.P. towards the right, with one of its edges at right angles to H.P. It is sectioned by a Horizontal Plane, 10 mm above its axis. Project its Front view and Sectional top view. 15

7. Draw to scale 1:1 the following views of the machine block shown pictorially in Fig. – 1 (Use First Angle projection method). 12
- i. Front view looking in the direction of arrow.
 - ii. Side view as seen from left
 - iii. Top view

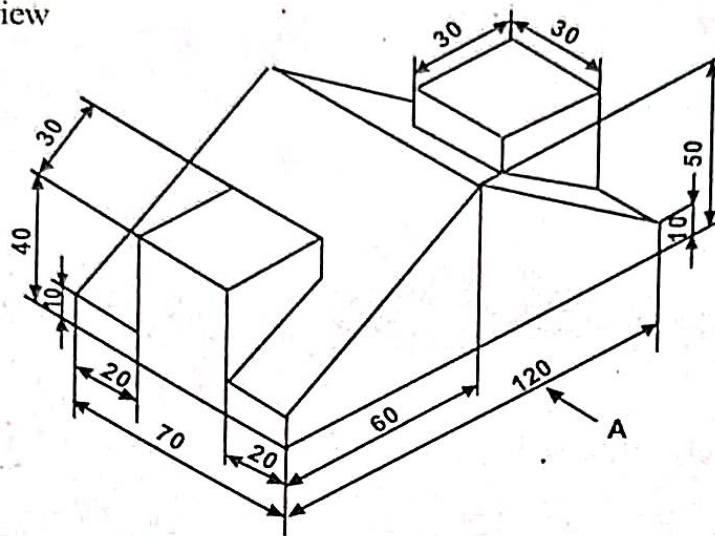

Figure – 1

8. Draw the Isometric projection of a pentagon with 38 mm side having its surface parallel to V.P. and perpendicular to H.P. 8
9. Draw the complete development of a regular Hexagonal prism of base edge = 25 mm and axis = 50mm long, resting on its base on H.P., and a rectangular face perpendicular to V.P. Give all dimensions. 5